

Mecal S.r.l.
Strada per Felizzano 18
I - 15043 Fubine (AL)
ph. +39 0131 792792
fax +39 0131 792733/4
www.mecal.net

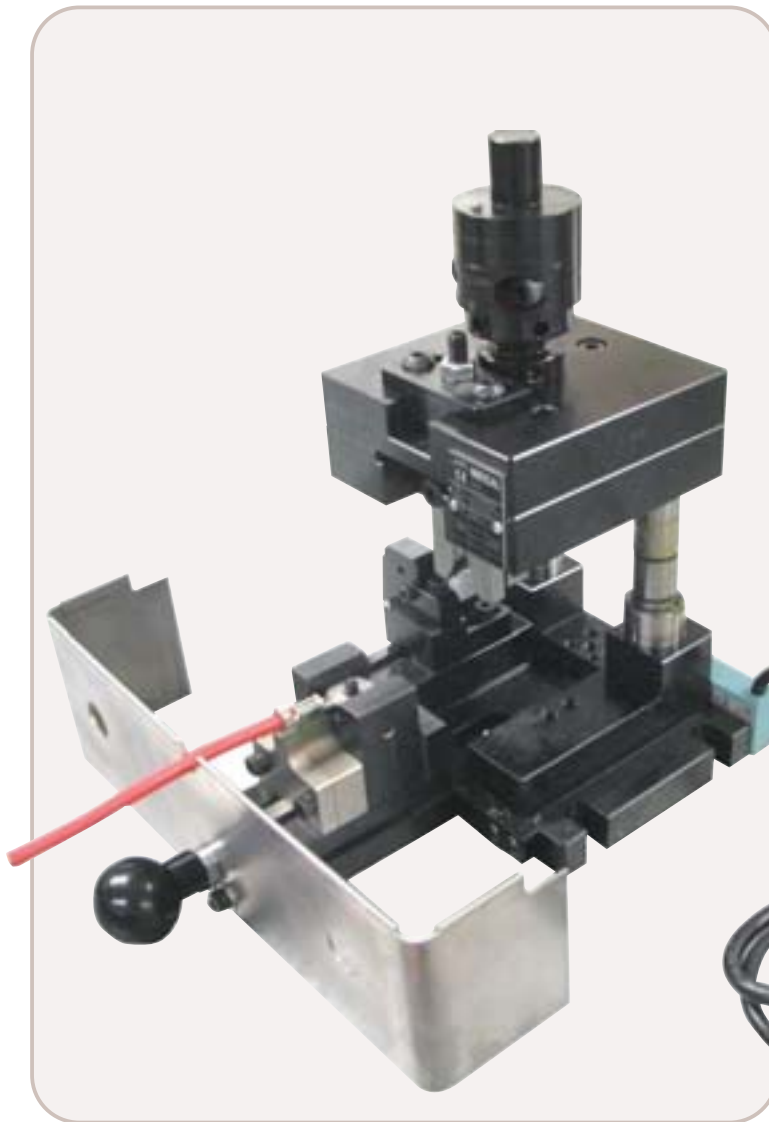

MSAS

Two-Post Die Loose terminals



Specifications

ID
MSAS

DESCRIPTION
Two-post die with manual feeding slide

CRIMPING HEIGHT
212 mm (8.346")

STROKE
50/40 mm (1.968/1.575")

TERMINAL THICKNESS
above 1.5 mm (0.059")

WIRE SECTION
up to 75 mm² (3/0 AWG)

FEEDING SYSTEM
manual

WEIGHT
13.6 Kg (29.9 lb)

DIMENSION (mm)
W (without carter) 170 x H 210 x D 200

DIMENSION (")
W 6.69 (without carter) x H 8.26 x D 7.87

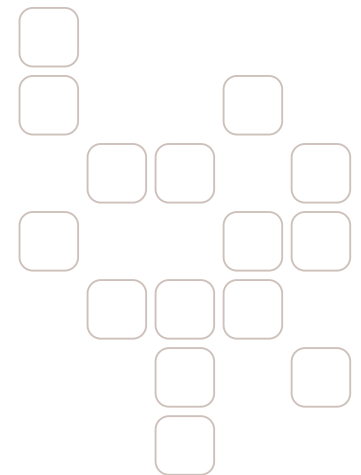

Two-post crimping die for big loose terminals with thickness > 1.5mm and wire section up to 75mm². Continuous crimping height adjusting system. The terminal is loaded by means of a manually operated slide, fitted with a sensor that allow the press to cycle only when the slide has reached its stroke's end. All the wearing parts can be replaced without removing the applicator from the press. Can be fitted to any crimping press having a crimping height (measured from the die mounting plate to the press coupling when at Bottom Dead Center) of 212mm (see Mecal Press P104). It is supplied with a complete technical documentation containing all the information needed to safely use and correctly maintain the equipment. Upon request, a capability study (including a picture of a sectioned crimped terminal) can be performed. Cycle counter non available.

Produced under a quality Management System certified to ISO 9001 (TUV).

Specifications subject to change. Consult Mecal S.r.l. for latest specifications.

Mecal S.r.l.
Strada per Felizzano 18
I- 15043 Fubine (AL)
ph. +39 0131 792792
fax +39 0131 792733/4
www.mecal.net



MSC Extreme Duty Two-Post Die

Extreme Duty Two-Post Die

Loose terminals



Specifications

ID
MSC

DESCRIPTION
Two-post die crimping height

CRIMPING HEIGHT
272 mm (10.7")

STROKE
50 mm (1.968")

TERMINAL THICKNESS
above 1.5 mm (above 0.059")

WIRE SECTION
75 mm² and above (3/0 AWG and above)

FEEDING SYSTEM
manual

WEIGHT
20.4 Kg (44.85 lb)

DIMENSION (mm)
W 250 x H 270 x D 197

DIMENSION (")
W 9.84 x H 10.6 x D 7.75



Azienda con Sistema Qualità
certificato N° 501001810



Two-post crimping die for big loose terminals with thickness > 1.5mm., wire section > 75mm². Can be used for coining. If fitted with the regulating head cod. 951270110, allows for a continuous setting of the crimping height, with a 0.1mm resolution and a 5.8mm range. All the wearing parts can be replaced without removing the applicator from the press. It is supplied with a complete technical documentation containing all the information needed to safely use and correctly maintain the equipment. Upon request, a capability study (including a picture of a sectioned crimped terminal) can be performed. Cycle counter non available. Must be used with Mecal P200 Crimping Press complete with its specific safety devices.

Produced under a quality Management System certified to ISO 9001 (TÜV).

Specifications subject to change. Consult Mecal S.r.l. for latest specifications.